

Operating Manual

Relative Air Humidity And Temperature Transducer

GHTU ... MP_{as of V2.6}



Specification:

Measuring range:	relative air humidity:	0.0...100.0 % rel. humidity (temperature compensated)
	temperature:	-40.0...120.0 °C or -40.0...248 °F
Rec. range of application:	standard:	20,0...80,0 %RH
	option high humidity:	5,0...95,0 %RH
Accuracy: (at nominal temperature = 25°C)		
Display	relative air humidity:	±1% linearity, 2% hysteresis
	temperature:	±0.4% of measured value ±0.2°C
Add. output signal:		±0.2 % FS
Sensors:	relative air humidity:	cap. polymer sensor
	temperature:	Pt1000
Temperature compensation:		automatic
Min-/Max-Value Memory:		Min and max measured values are stored
Output signals:		refer to type plate, both freely scaleable
Scaling:		By entering display values for 4mA (resp. 0V) and 20mA (resp. 1V/10V) output
Connection:		4 - 20 mA (2-wire) – output signals are electrically isolated from each other
	for option AV01, AV10:	0 - 1 (10) V (3-wire) – output signals are not electrically isolated from each other
	for option AV01G, AV10G:	0 - 1 (10) V (3- resp. 4-wire) – output signals are electrically isolated from each other
Auxiliary energy: (supply voltage, each output)		U _v = 12 - 30 V DC (4-20mA) U _v = 12 - 30 V DC, max. 10mA (0-1V) U _v = 18 - 30 V DC, max. 10mA (0-10V) or refer to type plate
Reverse voltage protection:		50V permanent
Perm. impedance (at 4-20mA):		$R_A(\text{Ohm}) < (U_v - 12V) / 0.02A$ Example: for U _v = 18V: $R_A < (18V - 12V) / 0.02A \Rightarrow R_A < 300 \text{ Ohm}$
Permissible load (at 0-...V):		$R_L(\text{Ohm}) > 3000 \text{ Ohm}$
Adjusting:		via keypress by input of offset and scale (humidity and temperature)
Display:		approx. 10 mm high, 4-digit LCD-display
Ambient conditions for electronics:		
Nominal temperature:		25°C
Operating temperature:		-25 to 50°C (sensor head and tube: -40 to 100°C – for short time up to 120°C)
Relative humidity:		0 to 95 %RH (non-condensing)
Storage temperature:		-25 to 70°C
Housing:		ABS (IP65)
Dimensions:		82 x 80 x 55 mm (without elbow-type plug and sensor tube)
Mounting:		With holes for wall mounting (in housing - accessible after cover has been removed).
Mounting distance:		50 x 70mm, max. shaft diameter of mounting screws is 4 mm.
Electrical connection:		elbow-type plug conforming to DIN 43650 (IP65), max. wire cross section: 1.5 mm ² , wire/cable diameter from 4.5 to 7 mm

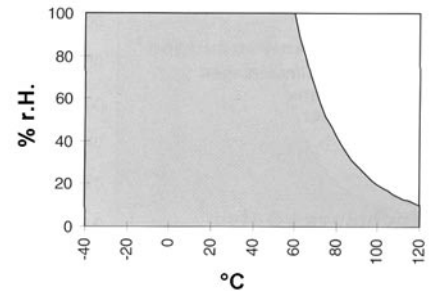

EMC: The device corresponds to the essential protection ratings established in the Regulations of the Council for the Approximation of Legislation for the member countries regarding electromagnetic compatibility (89/336/EWG). In accordance with EN61326 +A1 +A2 (appendix A, class B), additional errors: < 1% FS.
When connecting long leads adequate measures against voltage surges have to be taken.



GREISINGER electronic GmbH

Safety instructions:

This device has been designed and tested in accordance with the safety regulations for electronic devices. However, its trouble-free operation and reliability cannot be guaranteed unless the standard safety measures and special safety advises given in this manual will be adhered to when using the device.

1. Trouble-free operation and reliability of the device can only be guaranteed if the device is not subjected to any other climatic conditions than those stated under "Specification". If the device is transported from a cold to a warm environment condensation may cause in a failure of the function. In such a case make sure the device temperature has adjusted to the ambient temperature before trying a new start-up.
2. General instructions and safety regulations for electric, light and heavy current plants, including domestic safety regulations (e.g. VDE), have to be observed.
3. If device is to be connected to other devices (e.g. via PC) the circuitry has to be designed most carefully. Internal connection in third party devices (e.g. connection GND and earth) may result in not-permissible voltages impairing or destroying the device or another device connected.
4. If there is a risk whatsoever involved in running it, the device has to be switched off immediately and to be marked accordingly to avoid re-starting.
Operator safety may be a risk if:
 - there is visible damage to the device
 - the device is not working as specified
 - the device has been stored under unsuitable conditions for a longer time.
 In case of doubt, please return device to manufacturer for repair or maintenance.
5. **Warning:**
Do not use these product as safety or emergency stop devices, or in any other application where failure of the product could result in personal injury or material damage.
Failure to comply with these instructions could result in death or serious injury and material damage.

Disposal instructions:

The device must not be disposed in the regular domestic waste. Send the device directly to us (sufficiently stamped), if it should be disposed. We will dispose the device appropriate and environmentally sound.

Assignment of elbow-type plug: (depending on type)

4-20mA (2-wire connection)

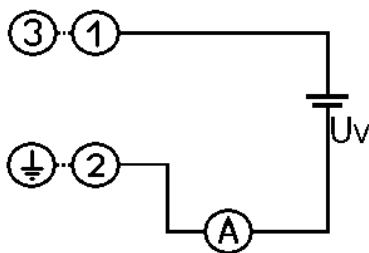

- 1 = supply voltage +Uv (humidity)
- 2 = GND / signal (humidity)
- 3 = supply voltage +Uv (temperature)
- ⊥ (4) = GND / signal (temperature)

voltage, not electrically isolated (3-wire connection)

(1 combined elbow type plug for humidity and temperature)

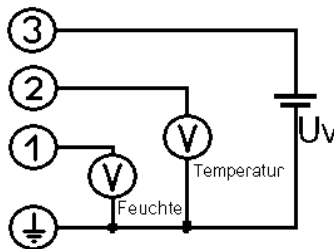

- 1 = signal + (humidity)
- 2 = signal + (temperature)
- 3 = supply voltage +Uv
- ⊥ (4) = supply voltage -Uv

voltage, electrically isolated (3- resp. 4-wire connection)

(2 elbow type plugs: right plug is for humidity left plug is for temperature)

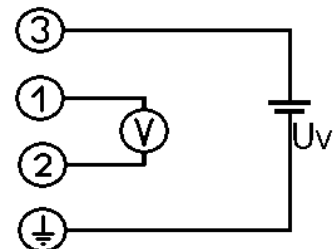

- 1 = signal + (humidity or temp.)
 - 2 = signal - (humidity or temp.)
 - 3 = supply voltage +Uv
 - ⊥ (4) = supply voltage -Uv
- (note: ⊥ and 2 are connected internally)

The type current or voltage output is set by works and cannot be changed

General installation instructions:

To mount the connection cable (2-, 3-, or 4-wire depending on type of device) the elbow-type plug screw has to be loosened and the coupling insert has to be removed by means of a screw driver at the position indicated (arrow). Pull out connection cable through PG glanding and connect to the loose coupling insert as described in the wiring diagram. Replace loose coupling insert onto the pins at the transducer housing and turn cover cap with PG glanding in the direction desired till it snaps on (4 different starting positions at 90° intervals). Re-tighten the screw at the angle plug.

Design types, dimension

Design type with 4-20mA output or voltage with not isolated outputs

GHTU-1R-MP
short sensor tube aside



GHTU-1K-MP
long sensor tube aside



GHTU-2K-MP
long sensor tube bottom

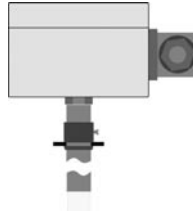

GHTU-MP-Kabel
separated sensor tube

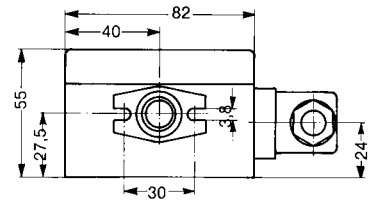

At design types with electrically isolated voltage outputs there are plugs at both sides (right plug for humidity, left plug for temperature)

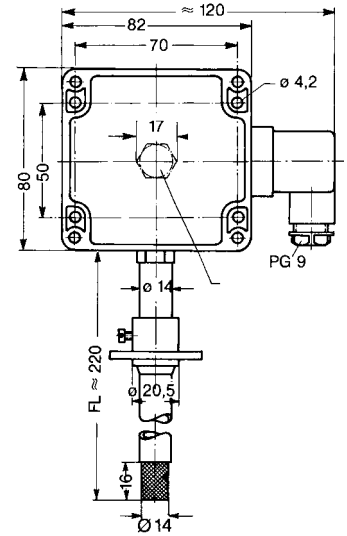
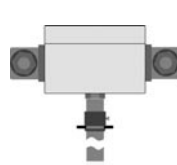

Display functions

Currently measured values

During normal operation the **relative air humidity** in [%RH] is displayed alternating to the **temperature** in [°C] or [°F].



display relative air humidity



display temperature

Arrow to Temp indicates temperature display

Min/Max Value Memory

watch Min values (Lo): press 'down'(2) shortly once

watch Max values (Hi): press 'up'(3) shortly once

restore current values: press 'down'(2) or 'up'(3) once again

clear Min-values: press 'down'(2) for 2 seconds

clear Max-values: press 'up'(3) for 2 seconds

After 10 seconds the currently measured values will be displayed again.

display changes between 'Lo' and Min values

display changes between 'Hi' and Max values

current values are displayed

Min values are cleared. The display shows shortly 'CLr'.

Max values are cleared. The display shows shortly 'CLr'.

Error and system messages

Display	Description	Possible fault cause	Remedy
Err.1	measuring range exceeded	Wrong signal	Temperature above 120°C not allowed.
Err.2	Measuring value below measuring range	Wrong signal	Temperature below -40°C not allowed.
Err.7	System fault	Error in device	Disconnect from supply and reconnect. If error remains: return to manufacturer
Err.9	Sensor error	Sensor or cable defective	Check sensor, cable and connections
Er.11	Calculation not possible	Calculation variable missing or invalid	Check temperature
8.8.8.8	Segment test	The transducer performs a display test for 2 seconds after power up. After that it will change to the display of the measuring.	

Configuration of the device

In the configuration following parameters can be changed:

- Display unit of temperature measuring
- Scaling of the humidity output and of the temperature output
- Adjusting of humidity and temperature display (offset and scale correction)

By means of the scaling the analogue signal outputs can be adopted to Your needs.

The adjusting by means of offset and scale is intended to be used to compensate errors of the measurements. It is recommended to keep the scale correction deactivated ("oFF"). The display value is given by following formula:

$$\text{Display} = \text{measured value} - \text{offset}$$

With a scale correction (just for calibration laboratories, etc) the formula changes:

$$\text{Display} = (\text{measured value} - \text{offset}) * (1 + \text{scale adjustment}/100)$$

To configure the parameters proceed like follows:

1. Press the key 1 (SET) for more than 4 sec's until **'unit' with temperature arrow** appears in the display.

I.) 'unit' with Temp-arrow: Temperature unit

Enter the desired Temperature unit. All referring settings and displays are done in this unit.

2. Choose the desired value by pressing 2 (down) or 3 (up) key. Choice between °C and °F (ex works: °C)
3. Enter by key 1 (SET), select next parameter by pressing key 1 again: **'Out.0' without temperature arrow** appears.

II.) 'Out.0': Display at zero output of humidity measuring (output scaling)

Enter the humidity value at which the output should have 4mA (respectively 0V).

4. Choose the desired value by pressing 2 (down) or 3 (up) key. Max. input range: 0.0...100.0 % (ex works: 0.0%)
5. Enter by pressing key 1 (SET), select next parameter: **'Out.1' without temperature arrow** appears in the display.

III.) 'Out.1': Display at maximum output for humidity measuring (output scaling)

Enter the humidity value at which the output should have 20mA (respectively 10V).

6. Choose the desired value by pressing 2 (down) or 3 (up) key. Max. input range: 0.0...100.0 % (ex works: 100.0%)
7. Enter by pressing key 1 (SET), select next parameter: **'Out.0' with temperature arrow** appears in the display.

IV.) 'Out.0' with Temp-arrow: Display at zero output of temperature measuring (output scaling)

Enter the temperature value at which the output should have 4mA (respectively 0V).

8. Choose the desired value by pressing 2 (down) or 3 (up) key. (ex works: 0.0°C / 32.0°F)
9. Enter by pressing key 1 (SET), select next parameter: **'Out.1' with temperature arrow** appears in the display.

V.) 'Out.1' with Temp-arrow: Display at maximum output for temperature measuring (output scaling)

Enter the temperature value at which the output should have 20mA (respectively 10V).

10. Choose the desired value by pressing 2 (down) or 3 (up) key. (ex works: 100.0°C / 212.0°F)
11. Enter by pressing key 1 (SET), select next parameter: **'OFFS' without temperature arrow** appears in the display.

VI.) 'OFFS': Offset of humidity measuring (correction of measuring deviations):

The offset of the measuring will be shifted by this value, the input is in %RH. Calculation: see above.

12. Choose the desired value by pressing 2 (down) or 3 (up) key.
Max. input range: -5.0...5.0 %RH or 'oFF': offset is deactivated (=0.0%, ex works)
13. Enter by pressing key 1 (SET), select next parameter: **'SCAL' without temperature arrow** appears in the display.

VII.) 'SCAL': Scale of humidity measuring (correction of measuring deviations):

The scale of the measuring is changed by this value. Calculation: see above.

14. Choose the desired value by pressing 2 (down) or 3 (up) key.
Max. input range: -5.00...5.00 or 'oFF': scale is deactivated (=0.00, ex works)
15. Enter by pressing key 1 (SET), select next parameter: **'OFFS' with temperature arrow** appears in the display.

VIII.) 'OFFS' with Temp-arrow: Offset of temperature measuring (correction of measuring deviations):

The offset of the measuring will be shifted by this value, the input is in °C. Calculation: see above.

16. Choose the desired value by pressing 2 (down) or 3 (up) key.
Max. input range: -5.0...5.0 °C / -9.0...9.0°F or 'oFF': offset is deactivated (=0.0, ex works)
17. Enter by pressing key 1 (SET), select next parameter: **'SCAL' with temperature arrow** appears in the display.

IX.) 'SCAL' with Temp-arrow: Scale of temperature measuring (correction of measuring deviations):

The scale of the measuring is changed by this value. Calculation: see above.

18. Choose the desired value by pressing 2 (down) or 3 (up) key.
Max. input range: -2.00...2.00 or 'oFF': scale is deactivated (=0.00, ex works)
19. Enter by pressing key 1 (SET). After pressing key 1 again, the instrument will restart (segment test).

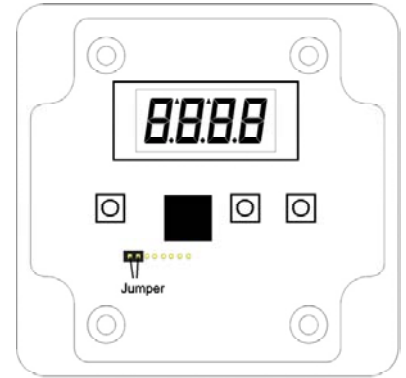

If the jumper is removed from the shown contacts, the configuration is inaccessible, values are protected.
Never connect other contacts!