

Product information

Flow - piston inline design

**Flow indicator
H1Z1 / H2Z1**



- No electrical supply required
- Individually calibrated display
- Compact design

Characteristics

A piston fitted with a magnet is pushed through the medium against the force of a spring. This activates the pointer of the measuring device by means of a magnetic coupling. Because of the hermetic separation from the medium, the display unit cannot be soiled by the medium.

Technical data

Switch	without	
Nominal width	DN 8..25	
Process connection	female thread G 1/4..G 1 (further process connections available on request)	
Display range	0.1..85 l/min	for details see table "Ranges"
Pressure loss	0.4..3.5 bar at Q _{max.}	
Q _{max.}	to 100 l/min	
Tolerance	±5 % of full scale value	
Pressure resistance	PN 200 bar optionally PN 500 bar	
Media temperature	-20..+120 °C	
Ambient temperature	-20..+70 °C	
Media	water, oil (gases and aggressive media available on request)	
Electrical data	none	
Materials medium-contact	Brass construction: CW614N nickelled, CW614N, 1.4310, hard ferrite, NBR	Stainless steel construction: 1.4571, 1.4404, 1.4310, hard ferrite PTFE-coated, FKM
Non-medium-contact materials	PC, acrylic	
Weight	see table "Dimensions and weights"	
Installation location	Standard: horizontal inwards flow from the left; other installation positions are possible; the installation position affects the display range.	

Ranges

Details in the table correspond to horizontal inwards flow with increasing flow rate.

Standard type H1Z1

Display range l/min H ₂ O	Q _{max.} recommended	Pressure loss bar at Q _{max.} H ₂ O
0.1 - 1.2	6	0.4
0.5 - 6.0	10	0.5
1.0 - 12.0	20	0.6
2.0 - 23.0	30	0.4
3.0 - 34.0	40	
4.0 - 45.0	60	0.8
6.0 - 65.0	80	1.4
20.0 - 85.0	100	1.6

Special ranges are available.

Viscosity compensated type H2Z1

Display range l/min oil 30..330 mm ² /s	Q _{max.} recommend ed	Pressure loss bar at Q _{max.} oil mm ² /s					Viscosity stability ±8 %, min.
		30	60	100	205	330	
0.5 - 10	12	1.1	1.4	1.6	2.8	3.5	±0.3 l/min
1.5 - 20	22	2.2	2.3	2.4			±0.5 l/min
2.5 - 30	35	1.9	2.0	2.1	2.3	2.9	±0.8 l/min
6.0 - 45	60					2.6	±2.7 l/min
12.0 - 65	80	2.1	2.3	2.4	2.6	2.8	±3.0 l/min

Special ranges are available.

Dimensions and weights

	G	Types	SW	X	Weight kg
Brass	G 1/4	H.Z1-008GM	40	15	1.3
	G 3/8	H.Z1-010GM			
	G 1/2	H.Z1-015GM		18	1.2
	G 3/4	H.Z1-020GM			
	G 1	H.Z1-025GM			
Stainless steel	G 1/4	H.Z1-008GK	41	15	1.3
	G 3/8	H.Z1-010GK			
	G 1/2	H.Z1-015GK		18	1.2
	G 3/4	H.Z1-020GK			
	G 1	H.Z1-025GK			

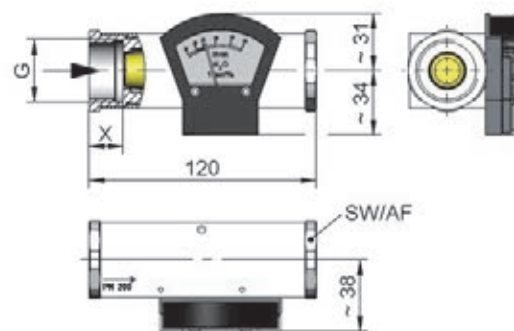

Product information

Flow - piston inline design

Handling and operation

- Include straight calming section of 5 x DN in inlet and outlet
- If the media are dirty, install a filter (use magnetic filter for ferritic components)

Ordering code

1. 2. 3. 4. 5. 6.
 H Z1 - G

1. Construction		
1	standard	
2	viscosity compensated	
2. Display		
Z1	with frontal measurement display Z1	
3. Nominal width		
008	DN 8 - G 1/4	
010	DN 10 - G 3/8	
015	DN 15 - G 1/2	
020	DN 20 - G 3/4	
025	DN 25 - G 1	
4. Process connection		
G	female thread	
5. Connection material		
M	brass	
K	stainless steel	
6. H1 - Display range H₂O for horizontal inwards flow		
001	0.1 - 1.2 l/min	●
005	0.5 - 6.0 l/min	●
010	1.0 - 12.0 l/min	●
020	2.0 - 23.0 l/min	●
030	3.0 - 34.0 l/min	●
040	4.0 - 45.0 l/min	●
060	6.0 - 65.0 l/min	●
080	20.0 - 85.0 l/min	●
H2 - display range oil 30..330 mm²/s for horizontal inwards flow		
008	0.5 - 10 l/min	●
015	1.5 - 20 l/min	●
025	2.5 - 30 l/min	●
040	6.0 - 45 l/min	●
060	12.0 - 65 l/min	●

Options

- Special ranges/special scaling
- Pressure resistance PN 500
- Temperature display 0..120 °C
- Reinforced piston

Ordering information

- Specify direction of flow, medium, and display range.
- For oils. State viscosity, temperature and designation (e.g. ISO VG 68) (enquire about display range).
- For gases, state pressure (relative or absolute), temperature and medium (e.g. air) (request display range)